

Comparing EIA-485 and EIA-422-A Line Drivers and Receivers in Multipoint Applications

Introduction

EIA-485 is a unique interface standard because, of all the EIA Standards, only EIA-485 allows for multiple driver operation. At first glance EIA-485 and EIA-422-A appear to be very similar. Thus, EIA-485 is commonly confused with EIA-422-A. EIA-485 components (drivers and receivers) are backward compatible with EIA-422-A devices and may be interchanged. However, EIA-422-A drivers should not be used in EIA-485 applications. This application note describes the differences between EIA-422-A and EIA-485 devices.

EIA-422-A drivers face three major problems if they are used in multipoint (multiple driver) applications. The first deals with the common mode range of the drivers. The TRI-STATE® common mode range for a EIA-422-A driver is -250 mV to $+6\text{V}$. If a ground potential difference exists between drivers as shown in *Figure 1*, the disabled driver can come out of its high impedance state and clamp the line to one diode drop below ground. The second problem deals with contention between active drivers. Faults may occur that cause two drivers to be enabled at the same time. If this happens and the drivers are in opposite states, high currents will flow between devices. The maximum package power dissipation ratings for the devices can be easily exceeded, thermally damaging the devices. The third problem deals with drive current. For bi-directional data flow, the line should be terminated with a resistor at both ends of the cable. Therefore drivers are required to source/sink twice the current required by an EIA-422-A termination (single resistor).

Problem #1—Common Mode Range

A typical bipolar EIA-422-A output structure is shown in *Figure 2*. Associated with the classical totem pole output structure is the parasitic substrate diode formed between the EPI layer and the substrate. This parasitic diode limits the negative common mode range of the driver's output. Given the case when the driver on the left is disabled (high impedance state), the driver on the right is active, and the two drivers are referenced to local grounds a fault can occur. If a ground potential difference exists between the two grounds (V_{CM}), the disabled driver can clamp the line. An example of this occurs when the disabled driver's ground is two volts higher in potential than the active driver's ground. If the output voltage goes below its ground by one diode drop, the parasitic diode becomes forward biased. For this example, assume a V_{OL} of 0.5V , and a V_{CM} of $+2\text{V}$. The active driver's V_{OL} is 0.5V , but with respect to the disabled driver's ground it becomes -1.5V . Clearly the EPI/SUB diode is forward biased and the line is clamped to -0.7V instead of the driven level. Data flow is not guaranteed, if the line is clamped. EIA-485 driver output structures, shown in *Figure 3*, include

National Semiconductor
Application Note 759
John Goldie
February 1991



a Schottky diode in both the source and sink side of the output structure. This diode isolates the EPI/SUB diode from the output pin, and eliminates the possibility of the parasitic diode from turning on and clamping the data line. The common mode range is now -7V to $+12\text{V}$ (7V from either rail). The adverse affects of this diode are minimal. The driver's V_{OL} is a Schottky diode drop higher, and V_{OH} is one diode drop lower. However, the driver's output will remain in a high impedance state for applied voltages between -7V and $+12\text{V}$.

Problem #2—Contention Between Drivers

If by hardware or software error two drivers are enabled at the same time, a fault occurs. In applications that use multiple drivers, protection from this fault should be considered. This fault can be more damaging to the drivers if the two active drivers are separated by a large ground potential difference. For example, transceiver one (T1) shown in *Figure 3* is referenced to earth ground GND1 (0V). While T2's ground potential (GND2) is 7V higher in magnitude with respect to GND1. If the two drivers are in opposite states, then a 12V difference exists between the drivers ($12\text{V} = V_{CM} + V_{CC}$). A large current will flow, and the maximum package power dissipation rating would be exceeded. EIA-422-A drivers do not have contention protection built in, since they are intended for use in single driver/multiple receiver applications. Power dissipation increases if multiple drivers are involved. EIA-485 line drivers are protected from this contention problem through the use of short circuit current limiting over a wide common mode range. Most EIA-485 drivers have a thermal shutdown feature (although not required by EIA-485). If an active EIA-485 driver output is shorted to any voltage between -7V and $+12\text{V}$, the resulting current will be less than 250 mA . Realizing that drivers can be thermally damaged, ALL National Semiconductor's EIA-485 drivers feature thermal shutdown protection (TS). For example, a worse case fault occurs if the driver is shorted to $+12\text{V}$, and the resulting current is 250 mA . The power dissipated on the device is simply current multiplied by voltage ($P=IV$): 12V (250 mA) = 3W . Three watts clearly exceeds the rated maximum package power dissipation specification for all common packages. However, the thermal shutdown feature senses this fault and disables the drivers output. Hence, the 250 mA current drops to 0 mA ; the device cools down and is automatically reset. If the fault is still present, the device will cycle into and out of thermal shutdown until the fault is removed. Some of National's devices feature an open collector pin that reports the occurrence of a thermal shutdown (DS3696 for example). EIA-422-A drivers would commonly incur damage when this fault occurs.

TRI-STATE® is a registered trademark of National Semiconductor Corporation.

Problem #2—Contention Between Drivers (Continued)

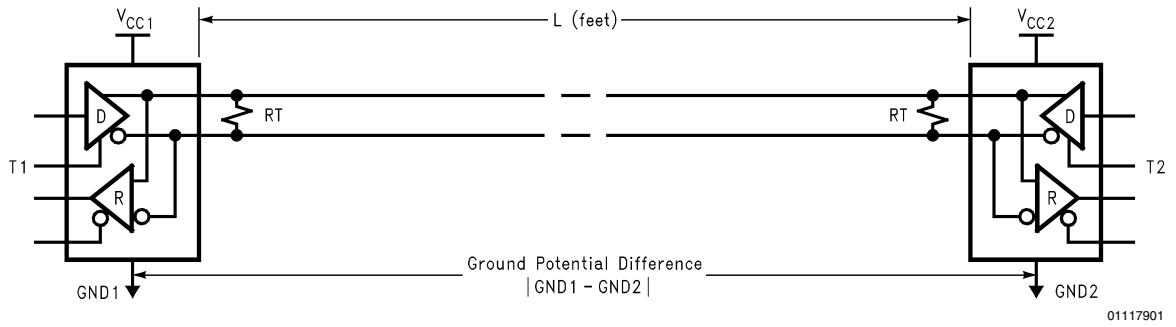

FIGURE 1. Typical Multiple Driver Application

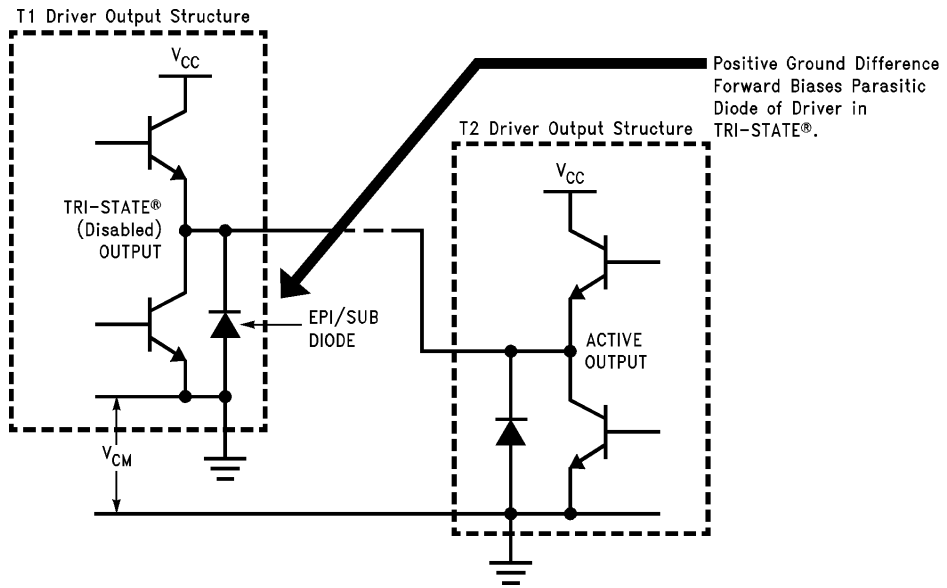

FIGURE 2. EIA-422-A Driver Output Structures Have A Limited Common Mode Range

Problem #2—Contention Between Drivers (Continued)

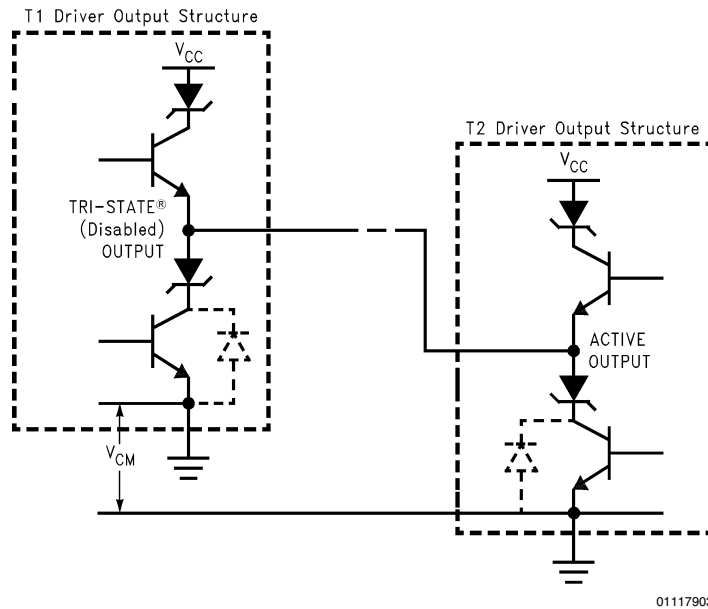

FIGURE 3. EIA-485 Driver Output Supports $-7V$ to $+12V$ Common Mode Range

Problem #3—Drive Current

The third problem deals with the drivers load current capability. EIA-422-A drivers are rated at ± 20 mA minimum, while EIA-485 devices have ± 55 mA minimum drive capability. Current sourced by the driver either flows through the termination resistor(s), or into receiver input structures. In multiple driver applications, two termination resistors (R_T) are required (one at each end of the cable), a driver would see these two resistors in parallel, resulting in a 60Ω load (assuming the termination resistors are 120Ω each). Receiver input structures are also seen in parallel by the driver, and the EIA-422-A receiver input impedance is also too low to be used in applications requiring a high number of receivers. To overcome these problems EIA-485 drivers have roughly three times the drive capability of EIA-422-A drivers. In addition EIA-485 receivers feature a higher input impedance, which is typically three times the EIA-422-A limit of $4\text{ k}\Omega$.

Conclusions

EIA-485 drivers are the best choice for multipoint (multiple driver) applications as shown in *Figure 4*. They can tolerate ground potential differences of up to $7V$ from either rail. They are contention safe and thermally protected. Finally, the drivers can handle up to 32 transceiver loads compared to EIA-422-A's limit of ten receivers. National offers a wide range of EIA-485 devices: Transceivers, Repeaters, Quad Drivers, Quad Receivers and Quad Transceivers are all

offered. Select devices are available in the Industrial and Military temperature ranges. National also offers MIL-883C qualified Quad Drivers, Quad Receivers and Transceiver (see the selection guide located in the front of chapter one of the Interface Databook for a complete listing of all EIA-485 Devices).

References

1. EIA Standard EIA-485 (RS-485), Standard for Electrical Characteristics of Generators and Receivers for use in a Balanced Digital Multipoint Systems, EIA, Washington, D.C.
2. EIA Standard EIA-422-A (EIA RS-422-A), Electrical Characteristics of Balanced Voltage Digital Interface Circuits, EIA, Washington, D.C.
3. Application Note 409, Transceivers and Repeaters Meeting the EIA RS-485 Interface Standard, Interface Databook, National Semiconductor, Santa Clara, CA.

EIA Standards can be obtained for a fee from:

Electronic Industries Association

EIA Engineering Department/Standard Sales Office

2001 Pennsylvania Avenue, N.W.

Washington, D.C. 20006

Tel: (202) 457-4988

References (Continued)

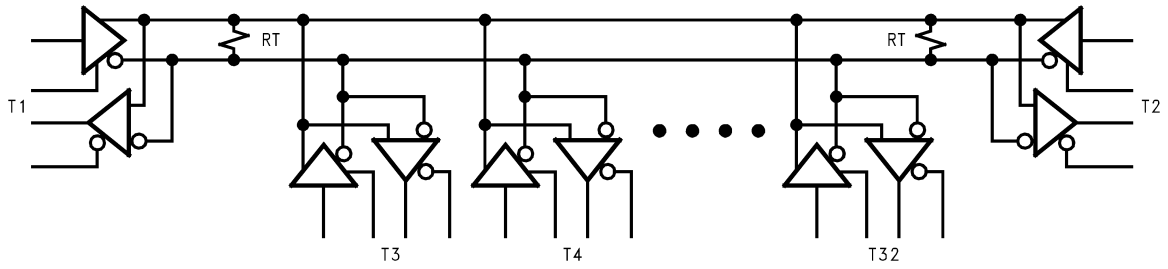

01117904

FIGURE 4. Typical EIA-485 Multipoint Application

LIFE SUPPORT POLICY

NATIONAL'S PRODUCTS ARE NOT AUTHORIZED FOR USE AS CRITICAL COMPONENTS IN LIFE SUPPORT DEVICES OR SYSTEMS WITHOUT THE EXPRESS WRITTEN APPROVAL OF THE PRESIDENT AND GENERAL COUNSEL OF NATIONAL SEMICONDUCTOR CORPORATION. As used herein:

1. Life support devices or systems are devices or systems which, (a) are intended for surgical implant into the body, or (b) support or sustain life, and whose failure to perform when properly used in accordance with instructions for use provided in the labeling, can be reasonably expected to result in a significant injury to the user.
2. A critical component is any component of a life support device or system whose failure to perform can be reasonably expected to cause the failure of the life support device or system, or to affect its safety or effectiveness.



National Semiconductor Corporation
Americas
Email: support@nsc.com

www.national.com

National Semiconductor Europe
Fax: +49 (0) 180-530 85 86
Email: europe.support@nsc.com
Deutsch Tel: +49 (0) 69 9508 6208
English Tel: +44 (0) 870 24 0 2171
Français Tel: +33 (0) 1 41 91 8790

National Semiconductor Asia Pacific Customer Response Group
Tel: 65-2544466
Fax: 65-2504466
Email: ap.support@nsc.com

National Semiconductor Japan Ltd.
Tel: 81-3-5639-7560
Fax: 81-3-5639-7507