

# Popular Connector Pin Assignments for Data Communication

## Introduction

This application note provides a graphical reference to popular connector pin assignments (pin outs) that are commonly used in telecom and computing applications.

In the field of data communication, the cable and connector play a critical part in the system's performance along with the line driver and receiver integrated circuits. Together the components (PCBs, ICs, cables, and connectors) form a channel, which all information must pass through. This channel forms a true chain, and a fault in any link may break the chain.

As stated in the introduction, this application note focuses on the connectors, and more specifically the pin assignments of the connectors. When equipment is built by a manufacturer and is intended to interwork with equipment from different manufacturers the use of an industry standard is critical. To

National Semiconductor  
 Application Note 917  
 John Goldie  
 Syed Huq  
 July 1998



properly inter-operate, the two pieces of equipment must support the same protocol (functional specifications), electrical levels, mechanical dimensions of the connector, and most importantly the connector's pin assignment. Since industry standards, TIA/EIA (Telecommunications Industry Association/Electronic Industries Association) for example, commonly specify or reference all three areas: Functional, Electrical, and Mechanical specifications, the chance of success is greatly increased when hooking up the two pieces of equipment.

A substantial amount of standardization work has been done in the telecommunications and computing area for interface standards. In addition to the connector pin outs, this application note also provides a short description of the standard or historical perspective. The reader is referenced to the actual standards from complete information on the standard.

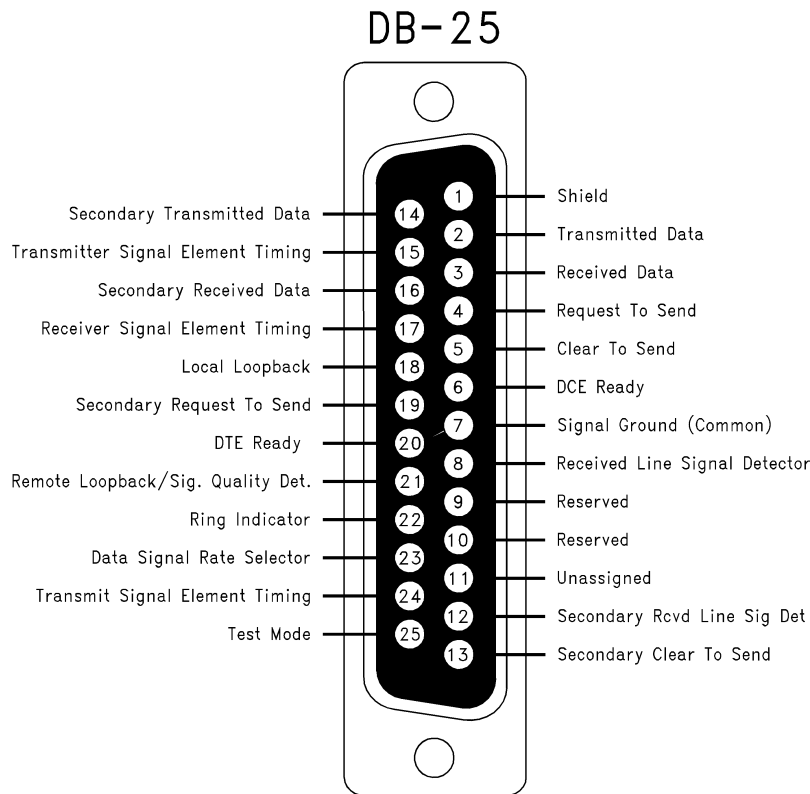

01194001

FIGURE 1. RS-232 DB-25

## Introduction (Continued)

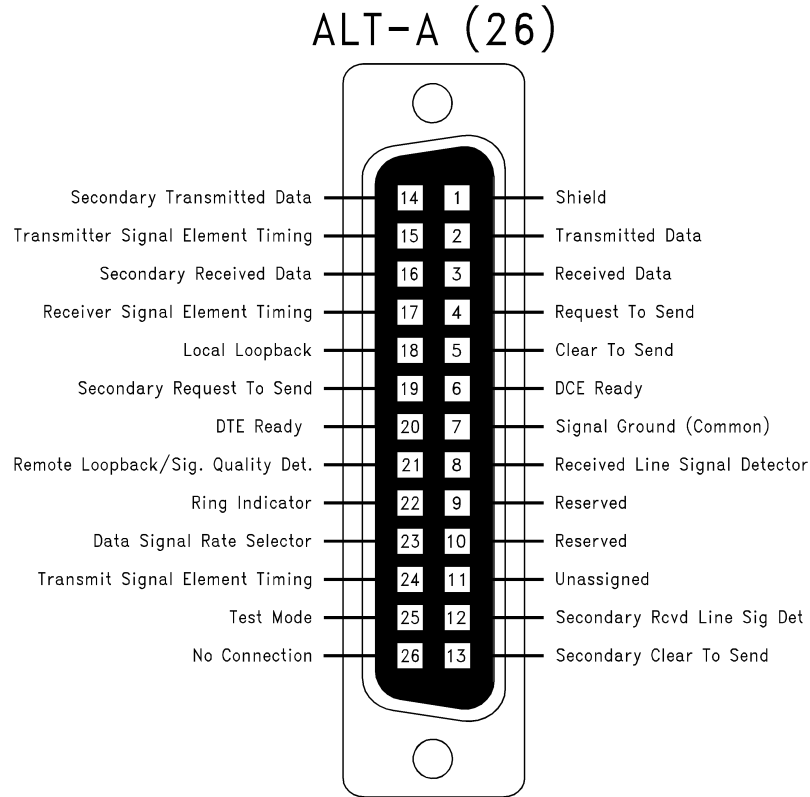

01194002

**FIGURE 2. RS-232 ALT-A**

### RS-232

RS-232 is one of the most popular interface standards in the world. Originally intended for DTE/DCE interfacing, this standard has been used in a wide range of applications including telecom, computing, test and measurement, and industrial control applications. Now in its fifth revision (E), RS-232 is still very popular, and new devices (line drivers and receivers) are being developed to support the standard. The correct name of the standard is EIA/TIA-232-E which has replaced the more common RS-232 nomenclature. This standard specifies two connectors, the standard DB-25, also a new smaller alternate connector with 26 pins. The original version of RS-232 dates back to the early 1960s and is known as a complete standard as it specifies all functional, electrical, and mechanical specifications. There is also a very popular 9 pin defacto version of this standard commonly employed on personal computers that was developed by IBM®. The two full (25 line) connector pin outs are shown on

Figure 1 and Figure 2. See Figure 7 for an illustration of the defacto 9 pin implementation, now standardized as EIA/TAI-574.

### RS-449

RS-449 was intended to replace RS-232 at one time. It also specifies a DTE/DCE interface, but references the RS-422-A and RS-423-A standards for electrical specifications. This standard specified a DB-37 pin connector along with an additional DB-9 pin connector when additional lines were required. The 37 pin connector proved too large for many applications and limited the acceptance of this interface. RS-449 is mainly found in high-end telecom applications but rarely elsewhere. It has been replaced with a new standard that specifies the common DB-25 connector (EIA/TIA-530-A). The pin out of the DB-37 pin connector is shown in Figure 3.

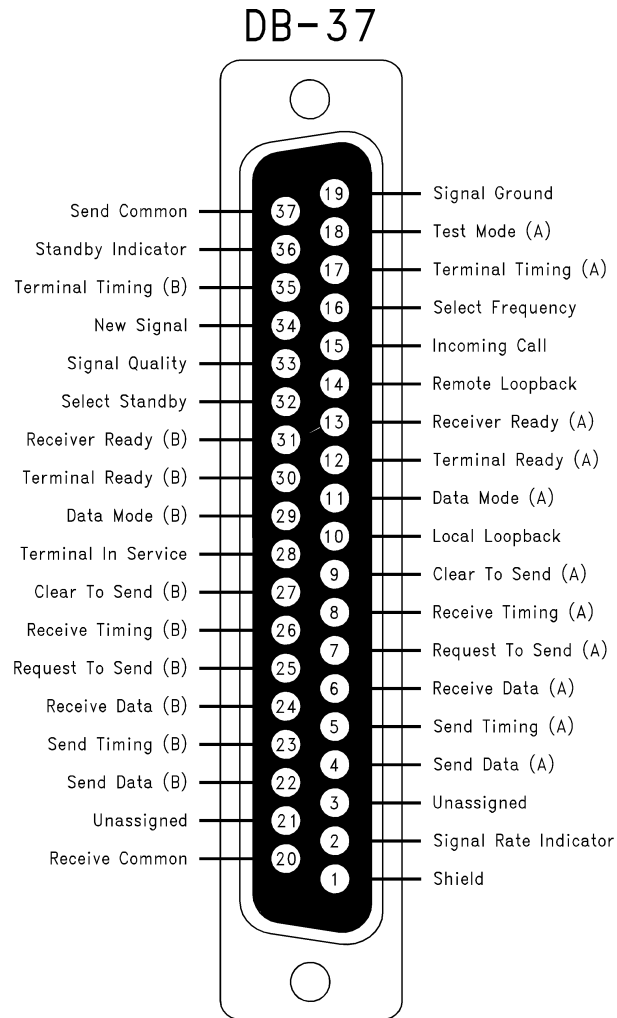

01194003

**FIGURE 3. RS-449 DB-37**

### EIA-530 and EIA/TIA-530-A

EIA-530 is an extension of RS-449 but is based on the DB-25 connector. This standard specifies both functional and mechanical specifications, and references RS-422-A and RS-423-A standards for electrical specifications. This

connector is the same one commonly used in EIA/TIA-232-E (RS-232) applications. This standard has been revised (denoted by the letter suffix — “A”), which altered the pin assignments slightly from EIA-530. Both pin assignments are shown in *Figure 4* and *Figure 5*.

EIA-530 and EIA/TIA-530-A (Continued)

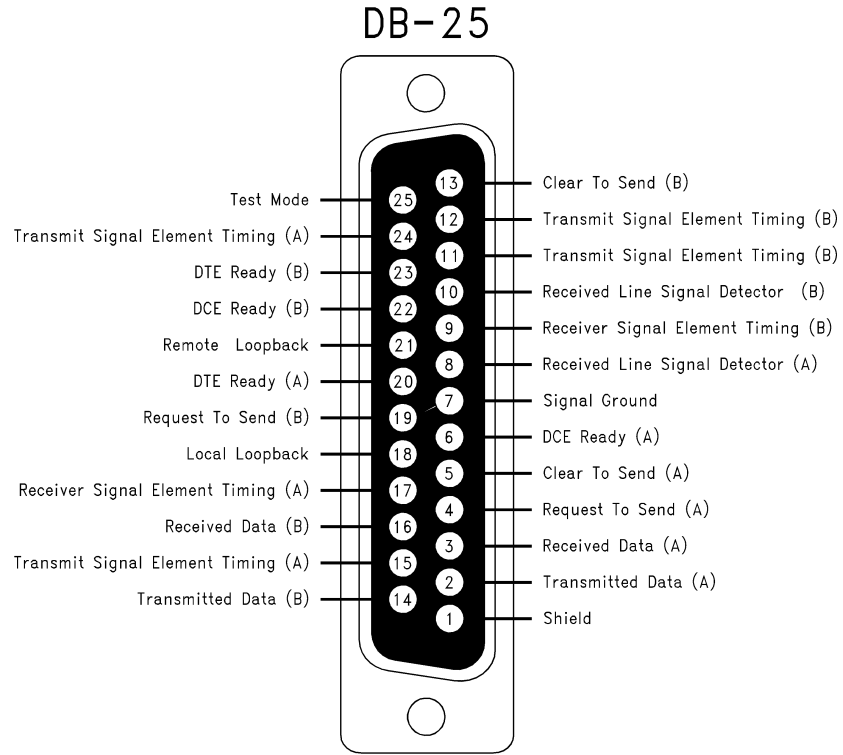

01194004

**FIGURE 4. EIA-530 DB-25**

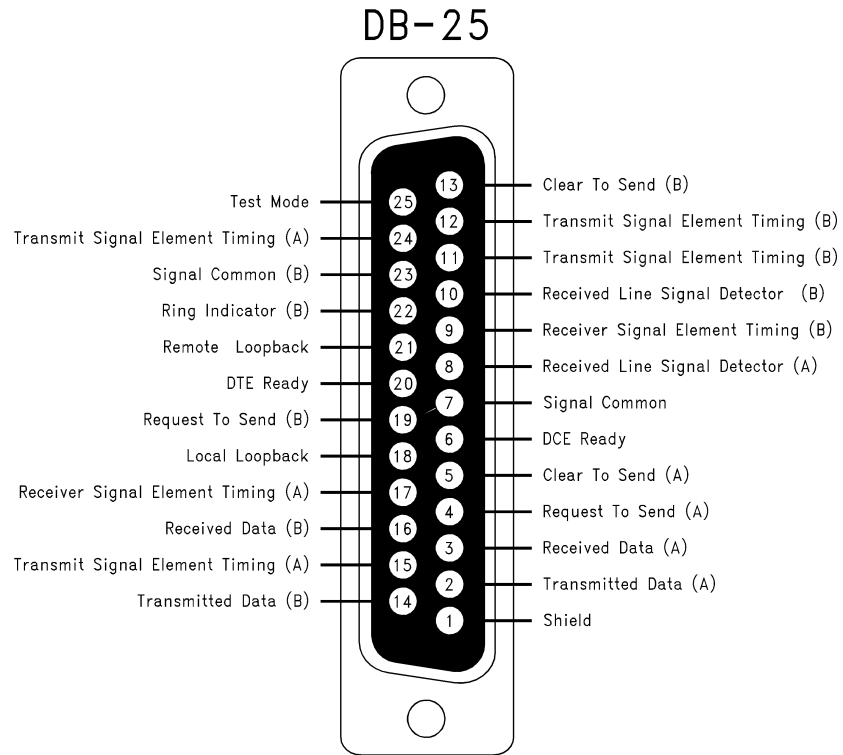

01194005

**FIGURE 5. EIA/TIA-530-A DB-25**

## EIA/TIA-561

EIA/TIA-561 is a new standard released in 1990 and specifies a small 8 position interface for non-synchronous interface between DTEs and DCEs. The uniqueness of this standard is the fact that it does not specify a DB style connector, but rather a modular receptacle and plug type connector. This standard references the companion standard EIA/TIA-562 for electrical levels (similar to RS-232 but lower power and faster). The plug and jack are shown in *Figure 6*.

Several other pin out options for the MJ connector exist. Most of these are proprietary implementations. Check with the specifications for the equipment that is being interfaced to. This will ensure inter-operation when employing an MJ connector.

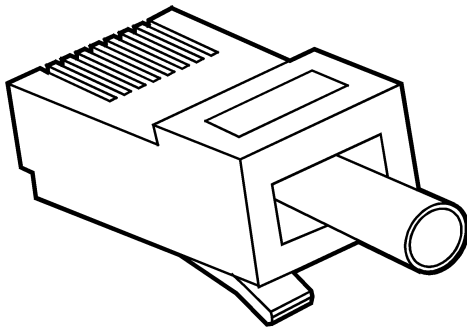

Plug

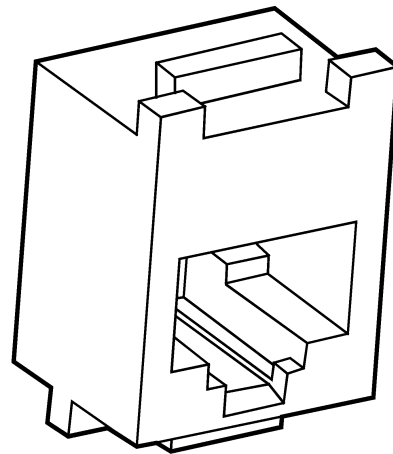

Receptacle

01194006

1. Ring Indicator
2. Received Line Signal Detector
3. DTE Ready
4. Signal Common
5. Received Data
6. Transmitted Data
7. Clear to Send
8. Request to Send/Ready for Receiving

**FIGURE 6. EIA/TIA-561 MJ-8**

## EIA/TIA-574

EIA/TIA-574 was developed due to confusion arising between the official RS-232 interface and the exceedingly popular defacto 9-pin version developed by IBM. This standard specifies the DB-9 interface, however, it recommends the use of the RS-562 standard instead of RS-232 electrical levels. It is noted that EIA/TIA-562 can inter-operate with RS-232 drivers and receivers in many applications. This standard supplies the minimum number of lines for non-synchronous serial data interchange between DTEs and DCEs. The connector pin out is shown in *Figure 7*.

as a high speed modem standard that also specified the DTE/DCE interface. This standard used RS-232 type line drivers and receivers for control circuits, and its own unique differential drivers and receivers for high speed data and timing lines. This recommendation specifies a unique connector and is shown in *Figure 8*. It should also be noted that the CCITT has been replaced with the ITU (International Telecommunications Union) and new standards will adopt the ITU prefix instead of CCITT.

## V.35

Recommendations V.35 was developed by the CCITT (International Telegraph and Telephone Consultative Committee)

V.35 (Continued)

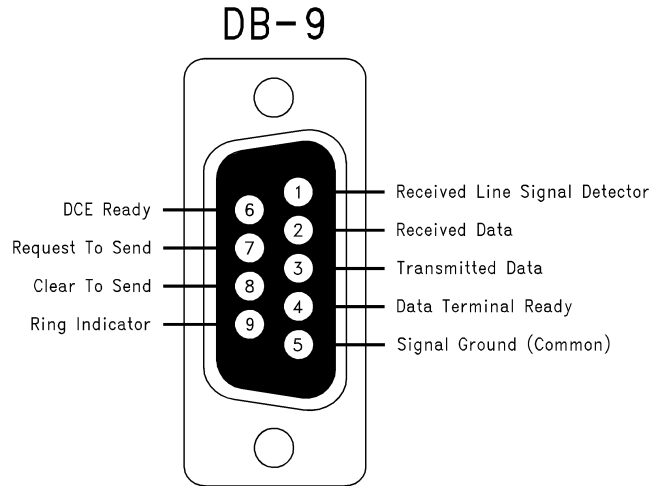

01194007

FIGURE 7. EIA/TIA-574 DB-9

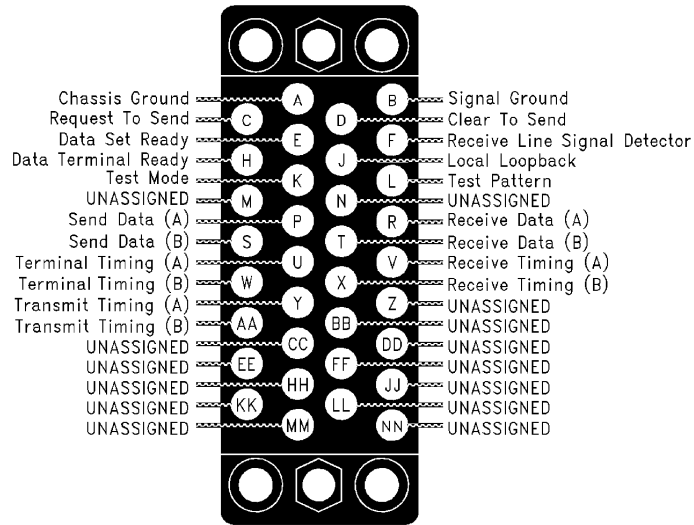

01194008

FIGURE 8. CCITT V.35

## IEEE-488

The IEEE (Institute of Electrical and Electronic Engineers) also standardizes many interfaces in the area of computing and instrumentation. IEEE-488 is a complete standard specifying all functional, electrical, and mechanical specifications for a 16 line parallel bus for instrumentation. This

interface is commonly found on test, and measurement equipment that feature computerized programming and control. This standard is also known under the acronym as GPIB (General Purpose Interface Bus). The pin out of the standardized connector is shown in *Figure 9*.

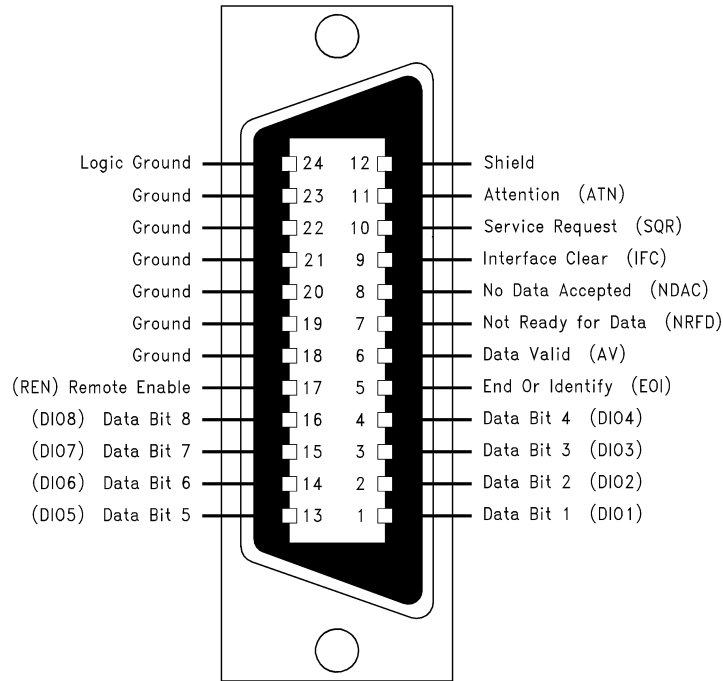

01194009

FIGURE 9. IEEE-488

## Centronics Port and IBM PC Parallel Port

These two defacto standards both specify parallel interface that are commonly used in computing applications (computer to peripheral-printer). Both are defacto standards, and support similar functions but different pin outs and mechani-

cal specifications. The IEEE has also defined a parallel port in the 1284 standard. It defines the 1284 connector and pin out (not shown here). The Centronics and IBM Parallel port pin outs are defined in the informational annexes of IEEE-1284. The two defacto connectors are shown in *Figure 10* and *Figure 11*.

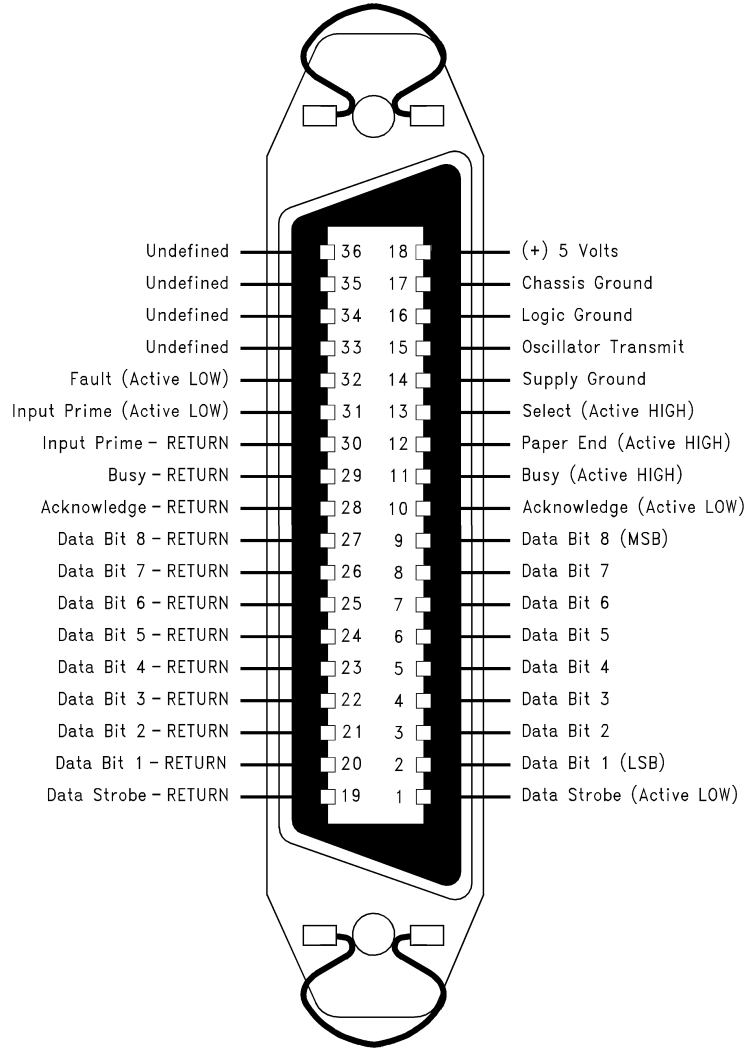

01194010

FIGURE 10. Centronics Port



## Centronics Port and IBM PC Parallel Port (Continued)

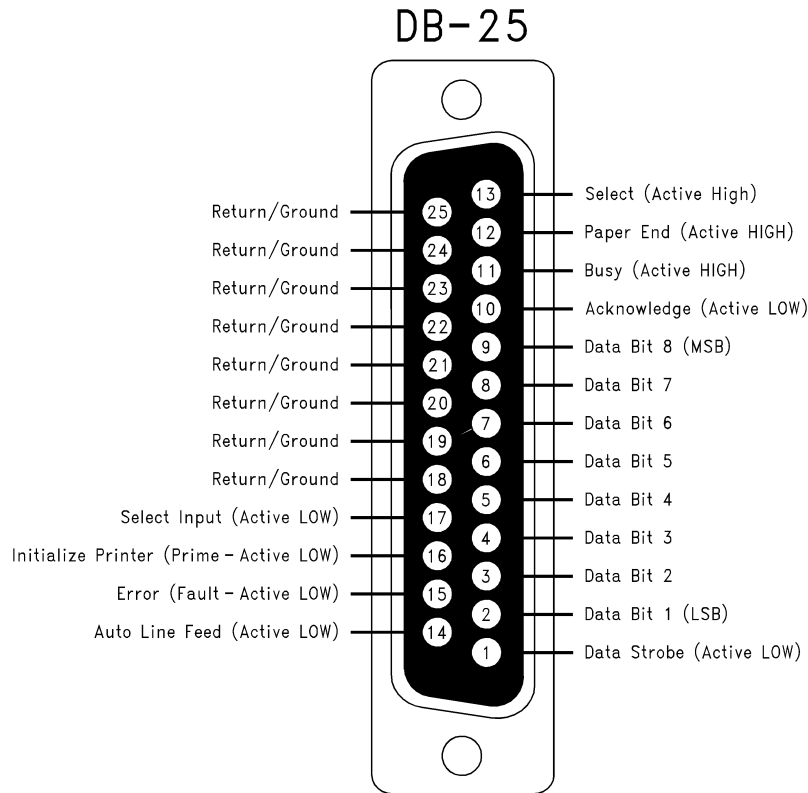

**FIGURE 11. IBM PC Parallel Port**

### Summary

By selecting an industry standard, the problem of getting signals from one board or box to another is greatly reduced. This is especially true when inter-operation between systems built by different manufacturers is required (open system).

Interface standards from the TIA/EIA and other standards groups greatly resolve this interfacing problem. This application note provides insight into those standards by providing a graphical representation of the connectors referenced in the standards. As always, whenever designing a system to an industry standard, a thorough review of the most recent revision of the standard is highly recommended.

### Reference

Most standards are available from:  
Global Engineering Documents

15 Inverness Way East  
Englewood, CO 80112-5704  
303-397-7956 or 800-854-7179  
<http://global.ihs.com/>

Various connector, cable and data communication products are available from:

South Hills Datacom  
Pittsburgh, PA, USA  
Toll-Free: 800-245-6215  
Local: 412-921-9000  
FAX: 412-921-2254

Notes

**LIFE SUPPORT POLICY**

NATIONAL'S PRODUCTS ARE NOT AUTHORIZED FOR USE AS CRITICAL COMPONENTS IN LIFE SUPPORT DEVICES OR SYSTEMS WITHOUT THE EXPRESS WRITTEN APPROVAL OF THE PRESIDENT AND GENERAL COUNSEL OF NATIONAL SEMICONDUCTOR CORPORATION. As used herein:

1. Life support devices or systems are devices or systems which, (a) are intended for surgical implant into the body, or (b) support or sustain life, and whose failure to perform when properly used in accordance with instructions for use provided in the labeling, can be reasonably expected to result in a significant injury to the user.
2. A critical component is any component of a life support device or system whose failure to perform can be reasonably expected to cause the failure of the life support device or system, or to affect its safety or effectiveness.



**National Semiconductor Corporation**  
Americas  
Email: support@nsc.com

www.national.com

**National Semiconductor Europe**  
Fax: +49 (0) 180-530 85 86  
Email: europe.support@nsc.com  
Deutsch Tel: +49 (0) 69 9508 6208  
English Tel: +44 (0) 870 24 0 2171  
Français Tel: +33 (0) 1 41 91 8790

**National Semiconductor Asia Pacific Customer Response Group**  
Tel: 65-2544466  
Fax: 65-2504466  
Email: ap.support@nsc.com

**National Semiconductor Japan Ltd.**  
Tel: 81-3-5639-7560  
Fax: 81-3-5639-7507